

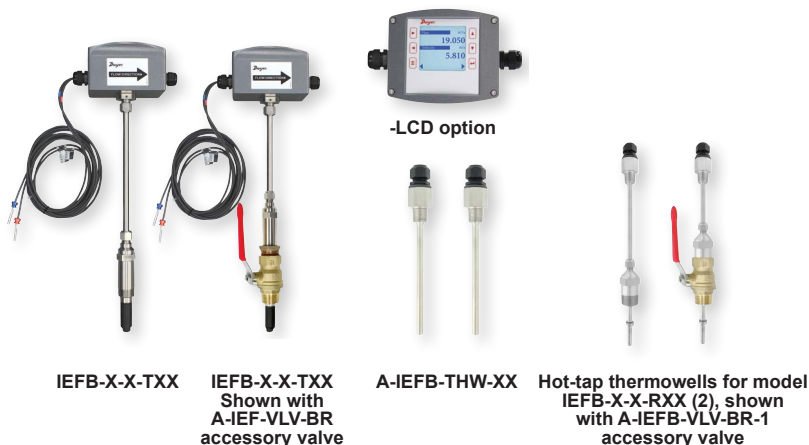

Series IEFB Insertion Thermal Energy Meter

Specifications - Installation and Operating Instructions

For full Installation and Operating Instructions refer to Bulletin F-IEFB at <http://www.dwyer-inst.com/Product/SeriesIEFB#literature>



IEFB-X-X-TXX

IEFB-X-X-TXX
Shown with
A-IEF-VLV-BR
accessory valve

A-IEFB-THW-XX

Hot-tap thermowells for model
IEFB-X-X-RXX (2), shown
with A-IEFB-VLV-BR-1
accessory valve

THERMOWELL MODEL CHART		
Model	A	B
A-IEFB-THW-4	4-11/16" (119.0 mm)	5-25/32 (146.8 mm)
A-IEFB-THW-6	6-11/16" (169.8 mm)	7-25/32 (197.6 mm)

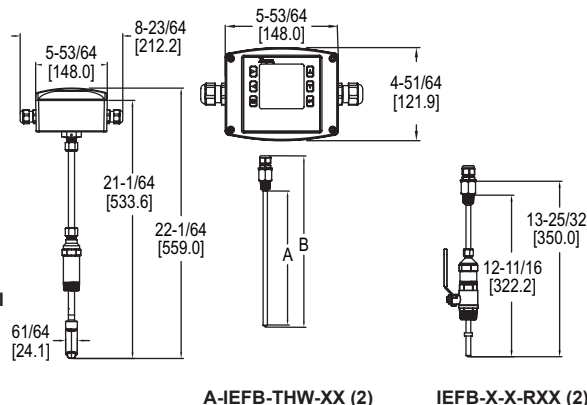

A-IEFB-THW-XX (2)

IEFB-X-X-RXX (2)

The **Series IEFB** is a field-adjustable insertion thermal energy meter that uses electromagnetic technology to accurately and reliably measure fluid velocity and energy consumption. The high accuracy IEFB is adjustable to fit pipe sizes from 4 to 10" (100 to 250 mm), while the standard accuracy IEFB fits pipe sizes 4 to 36" (100 to 900 mm). The flowmeter is simple to install and incorporates a temperature meter and an energy calculator into a single unit. The LCD display provides precise readings of the meter's values, including temperature and energy consumption, making it ideal for installation on chillers, boilers, and other heating and cooling applications. The high measuring accuracy and long lifetime keeps annual operating costs at a minimum. In addition, it offers several output options, including selectable BACnet MS/TP or Modbus® RTU communications protocol over 2-wire RS-485 and standard analog, frequency, and alarm outputs.

FEATURES/BENEFITS

- Flexible, field configurable setup displays (-LCD integral option or remote accessory A-IEF-DSP) accommodate a variety of application configurations. Application information is display selectable and includes pipe size, pipe material, liquid type, analog output, pulse/frequency output, alarm outputs, communication outputs, damping, and calibration factor
- High performance accuracy is maintained through changes in temperature, density and/or viscosity
- The Setup Wizard and installation tool are simple to use, providing quick and precise installation
- Accessory setup kit A-IEF-KIT comes with a thickness gage and measuring tape to ensure exact installation depth
- The meter has no moving parts and electrodes that discourage fouling, which gives the meter a long lifecycle and minimizes the need for maintenance
- Hot-tap isolation valve accessories allow for easy installation and removal in operational systems without system downtime

APPLICATIONS

- Monitoring chiller cooling output performance
- Industrial boiler heating performance
- Energy efficiency monitoring
- Optimization of heat energy performance
- Commercial and residential heat energy consumption and metering
- District heating and cooling monitoring
- Energy cost allocation monitoring

SPECIFICATIONS

Service: Compatible clean or dirty non coating, conductive liquids.

Range: 0 to 20 ft/s (0 to 6 m/s).*

Wetted Materials: Body shaft/fitting: 316 SS; Electrodes: 316 SS; Electrode cap: Polymer/polystyrene; O-ring: Silicone; Thermowells: 304 SS.

BTU Accuracy per EN1434/ASTM

E3137/CSA C900.1-13: High Accuracy Units: Class 2 for 2 to 20 ft/s (0.6 to 6 m/s)**; Standard Accuracy Units: Class 3 for 6.5 to 20 ft/s (2 to 6 m/s)**.

Flow Sensor Accuracy: High Accuracy Units: $\pm 0.5\%$ of reading at calibrated velocity, $\pm 1\%$ of reading from 2 to 20 ft/s (0.6 to 6 m/s) ± 0.02 ft/s (± 0.006 m/s) at < 2 ft/s (0.6 m/s); Standard Accuracy Units: $\pm 1\%$ FS.

Temperature Accuracy: Class B $\pm(0.30 + 0.005 \cdot t)^\circ\text{C}$ per EN60751.

Differential Temperature Accuracy: $\text{Et} = \pm(0.5 + 3 \cdot \Delta\theta_{\text{min}}/\Delta\theta) \%$ per EN1434.

Calculator Accuracy: $\text{Ec} = \pm(0.5 + \Delta\theta_{\text{min}}/\Delta\theta) \%$ per EN1434.

Temperature Compensation: 140 to 220°F (60 to 104.4°C) < 2% error over $\pm 30^\circ\text{F}$ (-1.1°C) change, 40 to 70°F (4.4 to 21.1°C) < 2% error over $\pm 10^\circ\text{F}$ (-12.2°C) change.

Temperature Limits: Ambient: -20 to 160°F (-29 to 71°C), -LCD -4 to 158°F (-20 to 70°C); Process: 15 to 250°F (-9 to 121°C); Storage: -40 to 185°F (-40 to 85°C).

Process Connection: Flowmeter: 1" NPT or BSPT with accessory full port ball valve options; Thermowell: (2) 1/2" NPT or BSPT thermowell with 1" full port ball valve options.

Pressure Limit: 400 psi (27.6 bar) @ 100°F (37.8°C).

Pressure Drop: < 0.1 psi at 12 ft/s in 4" (< 0.01 bar at 3.7 m/s in 100 mm) and larger pipe.

Outputs: (1) Analog: 4-20 mA, 0-5 V, 0-10 V or 2-10 V (display selectable); (1) Pulse/Frequency: 0-15 V peak pulse, 0-500 Hz or scalable pulse output (display selectable); (2) Alarm: Empty pipe detection or minimum/maximum velocity, (display selectable) & Reverse flow output indication.

*For max flowrates > 10 ft/s (3 m/s) order option -CC.

** Verified at standard temperature 73.4°F (23°C) refer to listed standards for detailed accuracy formulations.

Power Requirements: 12-42 VDC, .25 A @ 24 VDC; 12-36 VAC.

Electrical Connection: Removable terminal blocks, (2) model selectable 1/2" female NPT conduit connection, (2) PG 16 gland or (2) PG 16 gland with 10 ft (3 m) 9 conductor 22 AWG plenum rated cables, accessory cable lengths up to 200 ft (61 m) optional.

Display (-LCD option): 2 x 2" (50 x 50 mm) graphic LCD with backlight.

Conductivity: > 20 microsiemens.

Enclosure Material: Powder coated die cast aluminum.

Enclosure Ratings: NEMA 6P (IP68) (Non display models); NEMA 4X (IP66) (-LCD option).

Agency Approvals: BTL.

COMMUNICATIONS (-COM OPTION)

Type: BACnet MS/TP or Modbus®

RTU communication protocol (default disabled, display selectable).

Supported Baud Rates: 9600, 19200, 38400, 57600, 76800, or 115200 bps (display selectable).

Device Load: 1/8 unit load.

ADDITIONAL SPECIFICATIONS

Applicable Pipe Material: Most popular plastic and metal pipes; i.e. Carbon steel, SS, copper, UPVC/PVDF, galvanized steel, mild steel, and brass.

Applicable Pipe Size: 4 to 36" (100 to 900 mm), model dependent. See model chart.

Diameter Length Requirements: > 10 upstream, > 5 downstream.

Temperature Resistance: Matched 4 wire platinum RTD's.

Relative Humidity: 10 to 90% non-condensing.

Output Impedance: 4-20 mA: 536 Ω; 5V: 500 Ω; 10V: 1.27k Ω.

MODEL CHART							
Example	IEFB	-L	N	-CND	-R10	-LCD	IEFB-LN-CND-R10-LCD
Series	IEFB						Insertion thermal energy meter
Accuracy		L G S F I E T H					Standard accuracy <10" (250 mm) pipe; 1% FS Standard accuracy >10" (250 mm) pipe; 1% FS Standard accuracy 4 to 36" (100 to 900 mm) pipe; 1% FS High accuracy 4" (100 mm) pipe; 1% of reading High accuracy 6" (150 mm) pipe; 1% of reading High accuracy 8" (200 mm) pipe; 1% of reading High accuracy 10" (250 mm) pipe; 1% of reading High accuracy 4 to 10" (100 to 250 mm) pipe; 1% of reading
Process Connection			N B				1" Male NPT 1" Male BSPT
Housing Electrical Connection				CND PG 10			1/2" female NPT PG 16 gland without cable PG 16 gland with (2) 10' (3 m) plenum rated cables
Temperature Sensors					T10 T20 T50 R10 R20 R50		(2) 10' (3 m) PT temperature sensors* (2) 20' (6 m) PT temperature sensors* (2) 50' (15 m) PT temperature sensors* (2) 10' (3 m) PT temperature sensors with hot-tap thermowells (2) 20' (6 m) PT temperature sensors with hot-tap thermowells (2) 50' (15 m) PT temperature sensors with hot-tap thermowells
Options						LCD COM NIST FC CC	Integral LCD BACnet or Modbus® communications protocol NIST traceable calibration certification for flow and temperature Factory calibration certification, ±0.5% of reading at selected velocity Custom configuration (required input)
*Thermowells not included. Refer to thermowell accessory model chart to purchase permanent thermowells.							

ACCESSORIES	
Model	Description
Thermowells	
A-IEFB-THW-4	(2) 1/2" NPT, 4" (100 mm) thermowell for 4 to 7" (100 to 175 mm) pipe*
A-IEFB-THW-6	(2) 1/2" NPT, 6" (150 mm) thermowell for ≥8" (200 mm) pipe**
A-IEFB-THW-4-BSPT	(2) 1/2" BSPT, 4" (100 mm) thermowell for 4 to 7" (100 to 175 mm) pipe
A-IEFB-THW-6-BSPT	(2) 1/2" BSPT, 6" (150 mm) thermowell for ≥8" (200 mm) pipe
Hot-Tap Valves	
A-IEFB-VLV-BR-1	(2) 1" NPT full port isolation valve brass for temperature sensor with 1" branch outlet and 1" nipple
A-IEFB-VLV-SS-1	(2) 1" NPT full port isolation valve 316 SS for temperature sensor with 1" branch outlet and 1" nipple
A-IEFB-VLV-BR-1-BSPT	(2) 1" BSPT full port isolation valve brass for temperature sensor with 1" branch outlet and 1" nipple
A-IEFB-VLV-SS-1-BSPT	(2) 1" BSPT full port isolation valve 316 SS for temperature sensor with 1" branch outlet and 1" nipple
*4" (100 mm) standard thermowells for 1-1/2" stack height: 4 to 7" (100 to 175 mm) pipe size	
**6" (150 mm) standard thermowells for 1-1/2" stack height: 8 to 10" (200 to 350 mm) pipe size. Ideal insertion depth is 3" (80 mm)	

INCLUDED WITH THE SERIES IEFB INSERTION THERMAL ENERGY METER

- Carefully unpack the shipping container of your new Series IEFB Insertion Thermal Energy Meter and remove the following items:
 - (1) Series IEFB insertion thermal energy meter
 - (2) RTDs – Temperature measuring probes (not shown)
 - (1) A-IEF-INGD installation alignment kit:
 - (1) Alignment scale with captive thumbscrews
 - (2) Alignment rods (not shown)
 - (1) 3 mm Allen wrench (not shown, located in IEFB hanging tag)
 - (2) Hot tap thermowells (model dependent)
 - (1) Thermal paste (not shown)

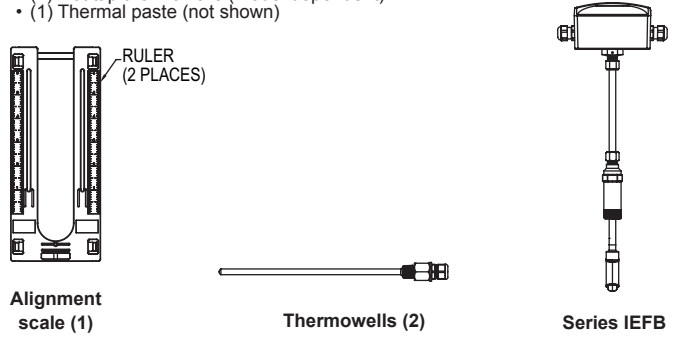

Figure 1: Included with IEFB

RECOMMENDED TOOLS

- (2) 12" (300 mm) adjustable wrenches
- (1) 12" (300 mm) pipe wrench

SETUP

Selecting Installation Location

- Although the unit may be installed in any orientation, the ideal mounting position is on the side of the pipe (2 o'clock or 10 o'clock position)* as this generally minimizes possible air or sediment interference with the Series IEFB. It is not recommended to mount the unit below the pipe (6 o'clock position).

NOTICE When installing a unit with an integral display select an installation location that allows for clear viewing of the display and earth ground.

- Insert the IEFB in a pipe via a threaded Tee, Saddle, or welded integrally reinforced branch connection outlet fitting.

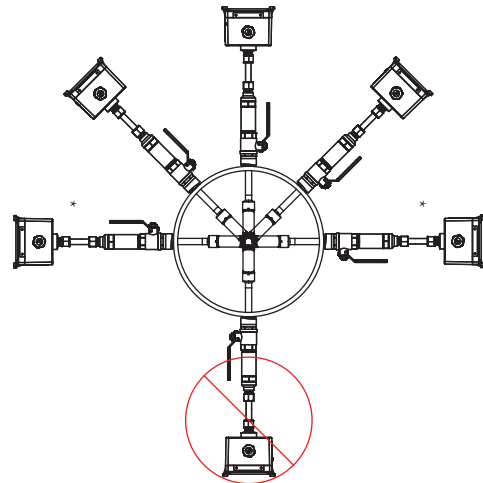

Figure 2: Proper installation orientation

- If a Hot-Tap option is required for the IEFB, use a 1-1/4" valve kit with proper mounting hardware available in Model A-IEF-VLV-BR or A-IEF-VLV-SS. A 1" (25 mm) hole in the pipe is required for proper installation.
- If a Hot-Tap option is required for the RTD thermowells, use a 1" valve kit with proper mounting hardware available in Model A-IEFB-VLV-BR-1 or A-IEFB-VLV-SS-1. A 1" (25 mm) hole in the pipe is required for proper installation.

3. Select a location that will minimize flow distortion with adequate upstream and downstream pipe diameters as displayed. Ideal installation will have a minimum of 10 pipe diameters upstream relative to the instrument and a minimum distance of 5 pipe diameters downstream.

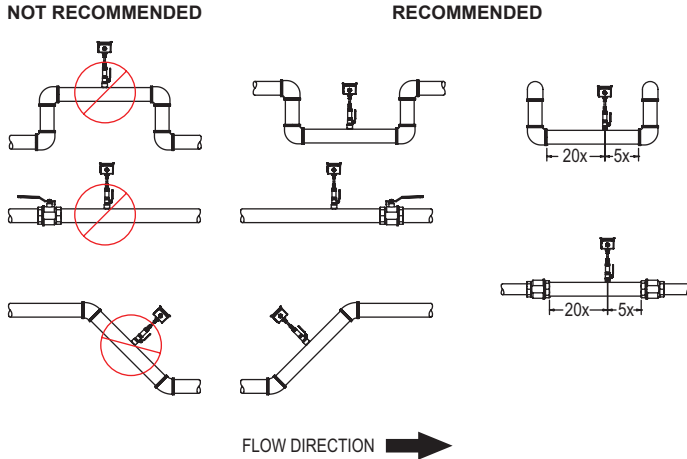

Figure 3: Proper installation location

IEFB THERMAL ENERGY METER INSTALLATION FLOWMETER INSTALLATION

1. To prepare the meter for installation, mount the provided alignment scale to the side of the meter using the two captured thumbscrews, finger tighten only. Be sure to orient the alignment scale as shown in Figure 5 below. Actual scale setting determined in next step.

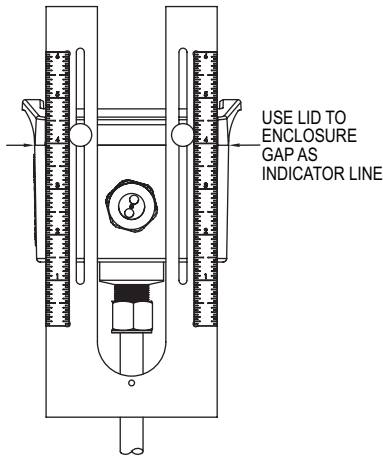

Figure 4: Alignment scale installed on IEFB

For Custom Configured Models (-CC Option)

2. Use the configuration tag attached to the Series IEFB to identify the value of the alignment scale setting. Position the alignment scale such that the scale setting is lined-up with the seam of the enclosure as shown in Figure 4. Securely tighten the thumbscrews.
3. Skip to Preparing the Unit for Installation.

Note: Minor scale marks are in 1/20ths.

For Field Configurable Models

2. For field configuration, a display is required (-LCD option or accessory A-IEF-DSP) and needs to be powered via normal field wiring or with the AC wall adapter accessory A-IEF-PA (A-IEF-DSP and A-IEF-PA are also available in the accessory setup kit A-IEF-KIT).
 - a. When using the AC wall adapter and the cable supplied, connect the red (positive +) and black (common -) wires of the cable bundle marked "A" to the open terminals of the AC wall adapter. This will provide temporary power to the meter to complete the installation set up.
 - b. For field wiring, refer to the wiring chart tag attached to the Series IEFB to identify the terminal block pins for positive (+) and common (-) connection. If prewired, refer to wiring chart located on the tag.
 - c. Unscrew the four captured cover screws using the supplied 3 mm Allen wrench to remove and set aside enclosure cover.
 - d. If using an A-IEF-DSP or the A-IEF-KIT, insert one connector of the ribbon cable supplied in the setup kit into the connector labeled "Display" in the middle of the unit. Be sure to orient the keying feature/ tab. See Figure 5 below:

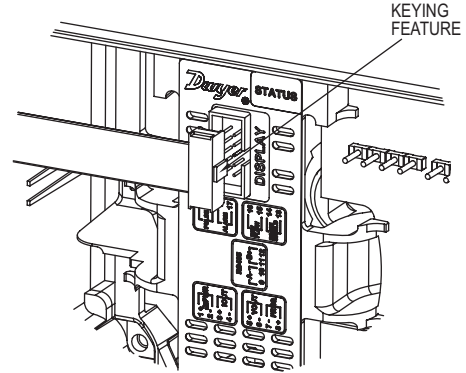

Figure 5: Connecting the display for field configurable models

4. Plug the other end of the cable into the bottom of A-IEF-DSP or A-IEF-KIT. Orient the keying feature/ tab as shown:

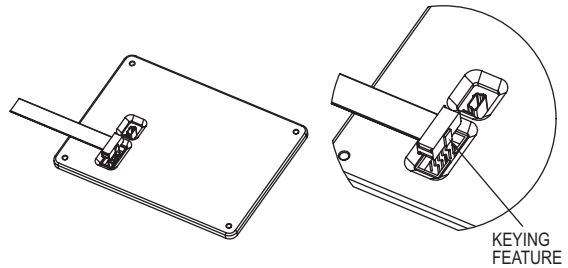

Figure 6: Keying feature

5. Apply power to the unit to turn on the display. Follow the on-screen directions for entering the necessary parameters to set up the unit. Obtain the alignment scale setting values and record them below:
A. IEFB "Alignment Scale Value"

These values will be used for the IEFB installation in a later step.

Preparing the Unit for Installation

NOTICE Precise pipe measurements are required for high performance installation. The A-IEF-KIT includes setup display A-IEF-DSP, thickness gage UTG and measuring tape A-IEF-MSTP used to obtain these measurements. When the precise pipe measurement information is known, select Option 2, High Performance setup, within the pipe setup menu.

NOTICE When using measuring tape A-IEF-MSTP to measure pipe circumference, use the 100ths side to measure the circumference of the pipe (without insulation).

Preparing the Unit for installation (Figure 8)

1. Apply appropriate sealant to the process collet threads (5) such as sealant tape or paste as suitable for the application.
2. Install the process collet (5) in valve (6), then tighten by hand.
3. Using the hex geometry, tighten the process collet (5) with a wrench to 180 in-lbs.
4. Slowly open the valve handle (7), checking for leaks. If leaks occur around threaded connections, close the valve and tighten those connections.

NOTICE Use two wrenches, one to hold the valve and another wrench to turn the process collet.

NOTICE Do not adjust housing compression nut at top of probe shaft (3).

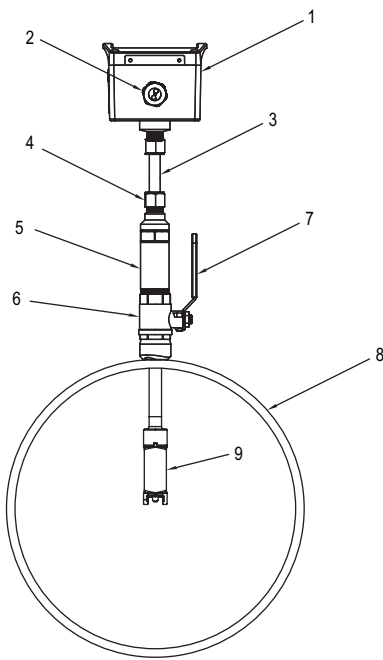

1. Enclosure
2. Cable Nut
3. Probe Shaft
4. Compression Fitting
5. Process Collet
6. Valve
7. Valve Handle
8. Pipe
9. Sensor Probe

Figure 7: Side system view

Sensor Alignment

A depth and flow alignment installation tool is provided to ensure proper depth insertion and flow alignment. To set the insertion depth, verify the alignment scale is set to the alignment scale value recorded previously as shown in figure 9 below. Loosen compression nut (4) to allow the shaft (3) freedom to travel up and down and rotate inside the process collet (5).

Install Depth and Alignment Rods

1. Remove alignment rods from sides of alignment scale by sliding them out.
2. Insert the two rods into the alignment scale as shown in Figure 8.

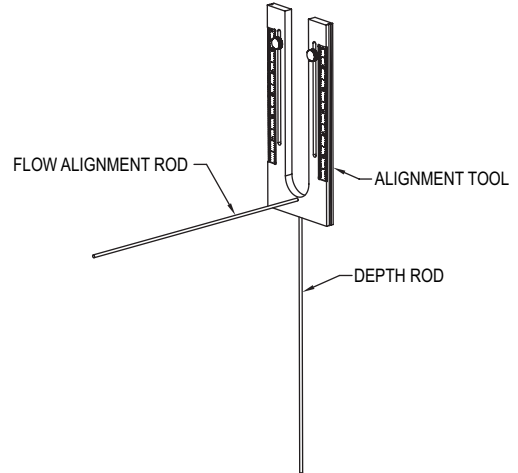

Figure 8: IEFB thermal energy meter alignment scale

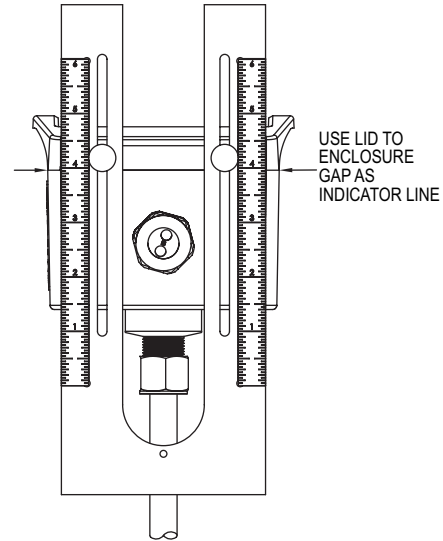

Figure 9: Alignment of scale on IEF lid

3. Rotate the meter so the pipe alignment rod is parallel with the flow in the pipe.

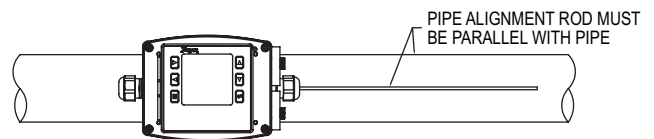

Figure 10: Flow alignment rod

4. Slide the shaft (3) down into the process collet (5) until the depth rod contacts the pipe. If pipe insulation is present, press the rod through the insulation.
 - a. Tighten the nut (4) to 180 in lbs. (20.3 N m)
 - b. Remove the flow alignment rod. Loosen the thumbscrews and slide the alignment tool up to remove of the depth alignment rod.
 - c. Store both rods in the storage slots on the sides of the alignment scale. Tighten thumbscrews and leave alignment tool mounted on unit for storage.

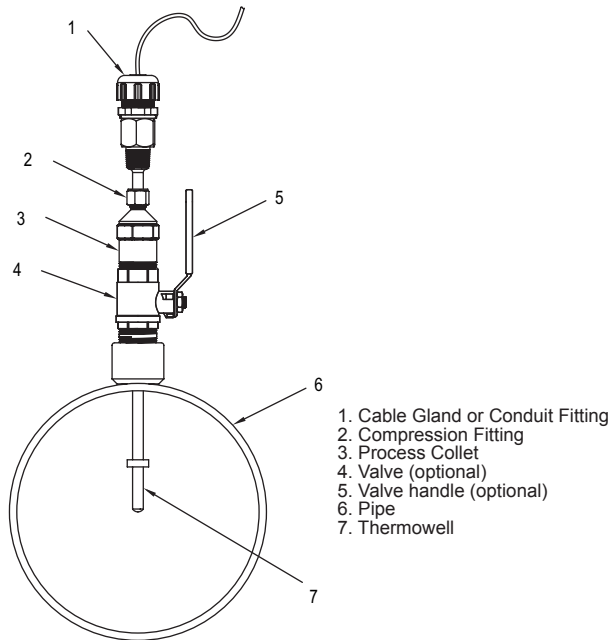

Figure 11: Hot tap installed in pipe cross section

Hot Tap Thermowell Sensor Depth

1. Insert the thermowell into the process collet (3) by loosening compression nut (2).
Screw into process valve (4) open the valve by turning valve handle (5).
2. Fully insert thermowell to maximum depth.
 - a. If thermowell makes contact with pipe ID, retract 1/4" (65 mm).
3. Tighten the nut (2) to 15 ft.-lbs (20.3 N m).
4. Repeat steps 1 through 3 for insertion of the second thermowell.

Note: For best accuracy, insulate the thermowells.

RTD INSTALLATION

The Series IEFB is provided with a matched pair of temperature sensors. These temperature sensors must be wired to the IEFB and properly installed into the accessory thermowells.

Cable Gland (PG 16) Thermowell (refer to Figure 14 below)

1. Remove compression nut (1) by unscrewing from cable gland (2).
2. Remove insert (3) from the cable gland (2).
3. Route the RTD through compression nut (1) and cable gland (2), then into the insert (3) and washer (4).

Note: Ensure insert (3) is aligned correctly, as shown in Figure 14 below.

4. Apply a generous coating of provided thermal paste onto the RTD.
5. For best accuracy, firmly insert the RTD into the thermowell, ensuring the tip of the RTD touches the bottom of the thermowell.
6. Screw the cable gland (2) into the thermowell.
7. Tighten the compression nut (1) onto the cable gland (2) to 30 in/lbs.

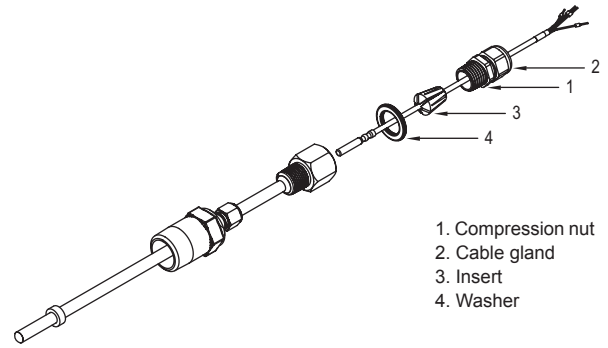

Figure 13: Thermowell assembly with PG gland

RTD INSTALLATION

Standard Thermowells

When installing temperature sensors in a new or drained fluid system, the IEFB uses standard thermowells.

For accurate energy usage measurement, the temperature sensors in the inlet and outlet must be located in ideal positions. One thermowell will be installed in the downstream run of pipe as the IEFB (minimum of 3" (75 mm) and no more than 12" (300 mm) from the flowmeter.) The second thermowell will be placed in the return path of the measured system.

Note: Ensure the selected locations for the thermowells are at suitable distances given the length of the RTD cable lengths provided.

Select the appropriate standard thermowell size for the application pipe size. 4" (100 mm) and 6" (150 mm) Standard Thermowells are available. The pipe size ranges are listed below:

4" (100 mm) Standard Thermowells for 1-1/2" Maximum Stack Height:
4 to 7" (100 to 175 mm) Pipe Size

6" (150 mm) Standard Thermowells for 1-1/2" Maximum Stack Height:
8 to 36" (200 to 250 mm) Pipe Size
Ideal insertion depth is 3"

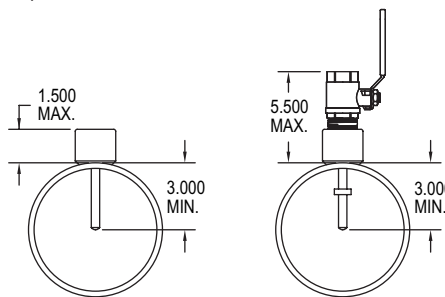

Figure 12: Stack height

Conduit Fitting Thermowell

1. Pull the RTD through the conduit.
2. Push the RTD through the conduit fitting. Route the RTD through compression nut (1) and conduit fitting (2), then into the insert (3) and washer (4).
3. Apply a generous coating of provided thermal paste onto the RTD.
4. Firmly insert the RTD into the thermowell ensuring the tip of the RTD touches the bottom of the thermowell.
5. Tighten the conduit fitting into the thermowell to 30 in/lbs.
6. Secure the conduit into the conduit fitting.

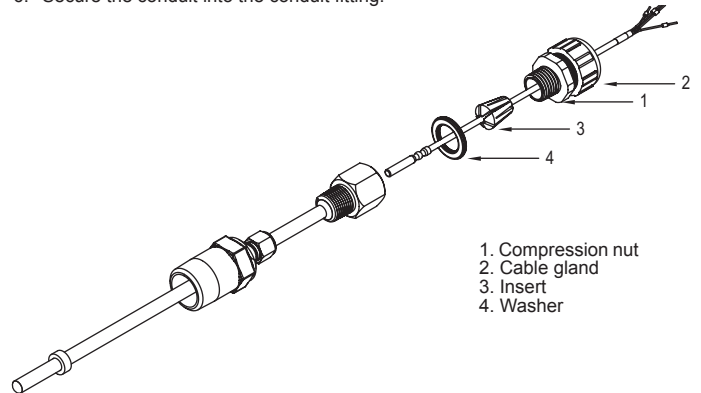

Figure 14: Thermowell assembly with CND gland

GROUNDING

Metallic Pipe

For proper operation, the IEFB must be earth grounded.

1. Connect a ground wire to meter housing via the ground lug on the housing collet.
2. Connect the ground wire to a known earth ground.
 - a. If the pipe is grounded, connect the ground wire to the pipe using suitable devices such as grounding clamps.

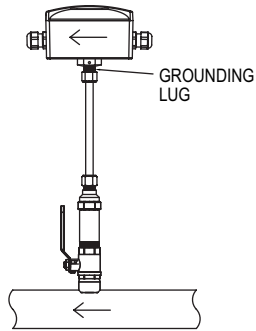

Figure 15: Metallic grounding

Non-Metallic Pipes

1. Connect a ground wire to the meter housing per the ground lug on the housing collet.
2. Connect the ground wire to a known earth ground.
3. Ground the fluid to earth.

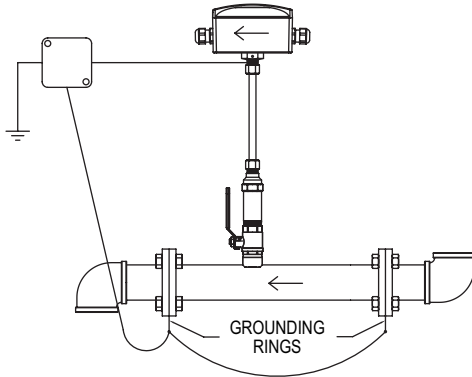

Figure 16: Non-metallic grounding

POWER SUPPLY

1. Choose a power supply with a voltage and current rating that meets the power specifications under all operating conditions.
2. If the power supply is unregulated, make sure the output voltage remains within the required voltage range under all power line conditions.